



Contactor relay, 2 NO + 2 NC, 230 V AC, 50 / 60 Hz, Size S00, screw terminal

| | |
|---|----------------------------|
| product brand name | SIRIUS |
| product designation | Auxiliary contactor |
| product type designation | 3RH2 |
| General technical data | |
| size of contactor | S00 |
| product extension auxiliary switch | Yes |
| power loss [W] for rated value of the current without load current share typical | 1.43 W |
| insulation voltage with degree of pollution 3 at AC rated value | 690 V |
| degree of pollution | 3 |
| surge voltage resistance rated value | 6 kV |
| shock resistance at rectangular impulse | |
| • at AC | 7,3g / 5 ms, 4,7g / 10 ms |
| shock resistance with sine pulse | |
| • at AC | 11,4g / 5 ms, 7,3g / 10 ms |
| mechanical service life (operating cycles) | |
| • of contactor typical | 30 000 000 |
| • of the contactor with added electronically optimized auxiliary switch block typical | 5 000 000 |
| • of the contactor with added auxiliary switch block typical | 10 000 000 |
| reference code according to IEC 81346-2 | K |
| Substance Prohibitance (Date) | 10/01/2009 |
| Ambient conditions | |
| installation altitude at height above sea level maximum | 2 000 m |
| ambient temperature | |
| • during operation | -25 ... +60 °C |
| • during storage | -55 ... +80 °C |
| relative humidity minimum | 10 % |
| relative humidity at 55 °C according to IEC 60068-2-30 maximum | 95 % |
| Environmental footprint | |
| Environmental Product Declaration (EPD) | Yes |
| Global Warming Potential [CO2 eq] total | 49.2 kg |
| Global Warming Potential [CO2 eq] during manufacturing | 1.15 kg |
| Global Warming Potential [CO2 eq] during operation | 48.2 kg |
| Global Warming Potential [CO2 eq] after end of life | -0.139 kg |
| Main circuit | |
| no-load switching frequency | |
| • at AC | 10 000 1/h |
| • at DC | 10 000 1/h |
| Control circuit/ Control | |

| | |
|---|--------------|
| type of voltage of the control supply voltage | AC |
| control supply voltage at AC | |
| • at 50 Hz rated value | 230 V |
| • at 60 Hz rated value | 230 V |
| control supply voltage frequency | |
| • 1 rated value | 50 Hz |
| • 2 rated value | 60 Hz |
| operating range factor control supply voltage rated value of magnet coil at AC | |
| • at 50 Hz | 0.8 ... 1.1 |
| • at 60 Hz | 0.85 ... 1.1 |
| apparent pick-up power of magnet coil at AC | 37 VA |
| inductive power factor with closing power of the coil | 0.8 |
| apparent holding power of magnet coil at AC | 5.7 VA |
| inductive power factor with the holding power of the coil | 0.25 |
| closing delay | |
| • at AC | 8 ... 33 ms |
| opening delay | |
| • at AC | 4 ... 15 ms |
| arcing time | 10 ... 15 ms |
| Auxiliary circuit | |
| number of NC contacts for auxiliary contacts | 2 |
| • instantaneous contact | 2 |
| number of NO contacts for auxiliary contacts | 2 |
| • instantaneous contact | 2 |
| identification number and letter for switching elements | 22 E |
| operational current at AC-12 maximum | 10 A |
| operational current at AC-15 | |
| • at 230 V rated value | 10 A |
| • at 400 V rated value | 3 A |
| • at 500 V rated value | 2 A |
| • at 690 V rated value | 1 A |
| operational current at 1 current path at DC-12 | |
| • at 24 V rated value | 10 A |
| • at 110 V rated value | 3 A |
| • at 220 V rated value | 1 A |
| • at 440 V rated value | 0.3 A |
| • at 600 V rated value | 0.15 A |
| operational current with 2 current paths in series at DC-12 | |
| • at 24 V rated value | 10 A |
| • at 60 V rated value | 10 A |
| • at 110 V rated value | 4 A |
| • at 220 V rated value | 2 A |
| • at 440 V rated value | 1.3 A |
| • at 600 V rated value | 0.65 A |
| operational current with 3 current paths in series at DC-12 | |
| • at 24 V rated value | 10 A |
| • at 60 V rated value | 10 A |
| • at 110 V rated value | 10 A |
| • at 220 V rated value | 3.6 A |
| • at 440 V rated value | 2.5 A |
| • at 600 V rated value | 1.8 A |
| operating frequency at DC-12 maximum | 1 000 1/h |
| operational current at 1 current path at DC-13 | |
| • at 24 V rated value | 10 A |
| • at 110 V rated value | 1 A |
| • at 220 V rated value | 0.3 A |
| • at 440 V rated value | 0.14 A |
| • at 600 V rated value | 0.1 A |
| operational current with 2 current paths in series at DC-13 | |
| • at 24 V rated value | 10 A |

| | |
|---|---|
| <ul style="list-style-type: none"> • at 60 V rated value • at 110 V rated value • at 220 V rated value • at 440 V rated value • at 600 V rated value | 3.5 A 1.3 A 0.9 A 0.2 A 0.1 A |
| operational current with 3 current paths in series at DC-13 | |
| <ul style="list-style-type: none"> • at 24 V rated value • at 60 V rated value • at 110 V rated value • at 220 V rated value • at 440 V rated value • at 600 V rated value | 10 A 4.7 A 3 A 1.2 A 0.5 A 0.26 A |
| operating frequency at DC-13 maximum | 1 000 1/h |
| design of the miniature circuit breaker for short-circuit protection of the auxiliary circuit up to 230 V | C characteristic: 6 A; 0.4 kA |
| contact reliability of auxiliary contacts | 1 faulty switching per 100 million (17 V, 1 mA) |
| UL/CSA ratings | |
| contact rating of auxiliary contacts according to UL | A600 / Q600 |
| Short-circuit protection | |
| design of the fuse link for short-circuit protection of the auxiliary switch required | fuse gL/gG: 10 A |
| Installation/ mounting/ dimensions | |
| mounting position | +/-180° rotation possible on vertical mounting surface; can be tilted forward and backward by +/- 22.5° on vertical mounting surface |
| fastening method | screw and snap-on mounting onto 35 mm DIN rail |
| height | 57.5 mm |
| width | 45 mm |
| depth | 73 mm |
| required spacing | |
| <ul style="list-style-type: none"> • with side-by-side mounting <ul style="list-style-type: none"> — forwards — upwards — downwards — at the side • for grounded parts <ul style="list-style-type: none"> — forwards — upwards — at the side — downwards • for live parts <ul style="list-style-type: none"> — forwards — upwards — downwards — at the side | 10 mm 10 mm 10 mm 0 mm 10 mm 10 mm 6 mm 10 mm 10 mm 10 mm 10 mm 6 mm |
| Connections/ Terminals | |
| type of electrical connection for auxiliary and control circuit | screw-type terminals |
| type of connectable conductor cross-sections | |
| <ul style="list-style-type: none"> • for auxiliary contacts <ul style="list-style-type: none"> — solid or stranded — finely stranded with core end processing • for AWG cables for auxiliary contacts | 2x (0.5 ... 1.5 mm ²), 2x (0.75 ... 2.5 mm ²), 2x 4 mm ² 2x (0.5 ... 1.5 mm ²), 2x (0.75 ... 2.5 mm ²) 2x (20 ... 16), 2x (18 ... 14), 2x 12 |
| Safety related data | |
| product function | |
| <ul style="list-style-type: none"> • positively driven operation according to IEC 60947-5-1 • suitable for safety function | Yes Yes |
| suitability for use safety-related switching OFF | Yes |
| service life maximum | 20 a |
| proportion of dangerous failures | |
| <ul style="list-style-type: none"> • with low demand rate according to SN 31920 • with high demand rate according to SN 31920 | 40 % 73 % |
| B10 value with high demand rate according to SN 31920 | 1 000 000; With 0.3 x I _e |

| | |
|---|--|
| failure rate [FIT] with low demand rate according to SN 31920 | 100 FIT |
| ISO 13849 | |
| device type according to ISO 13849-1 | 3 |
| overdimensioning according to ISO 13849-2 necessary | Yes |
| IEC 61508 | |
| safety device type according to IEC 61508-2 | Type A |
| Electrical Safety | |
| protection class IP on the front according to IEC 60529 | IP20 |
| touch protection on the front according to IEC 60529 | finger-safe, for vertical contact from the front |
| Approvals Certificates | |
| General Product Approval | |



[Confirmation](#)



[KC](#)

| | | | | |
|--------------------------|-----|-------------------|-------------------|-------------------|
| General Product Approval | EMV | Functional Safety | Test Certificates | Marine / Shipping |
|--------------------------|-----|-------------------|-------------------|-------------------|



[Type Examination Certificate](#)

[Type Test Certificates/Test Report](#)

[Special Test Certificate](#)



| | |
|-------------------|-------|
| Marine / Shipping | other |
|-------------------|-------|



[Miscellaneous](#)

| | | |
|-------|---------|-------------|
| other | Railway | Environment |
|-------|---------|-------------|

[Confirmation](#)

[Special Test Certificate](#)



Further information

Information on the packaging

<https://support.industry.siemens.com/cs/ww/en/view/109813875>

Information- and Downloadcenter (Catalogs, Brochures,...)

<https://www.siemens.com/ic10>

Industry Mall (Online ordering system)

<https://mall.industry.siemens.com/mall/en/en/Catalog/product?mlfb=3RH2122-1AP00>

Cax online generator

<http://support.automation.siemens.com/WW/CAXorder/default.aspx?lang=en&mlfb=3RH2122-1AP00>

Service&Support (Manuals, Certificates, Characteristics, FAQs,...)

<https://support.industry.siemens.com/cs/ww/en/ps/3RH2122-1AP00>

Image database (product images, 2D dimension drawings, 3D models, device circuit diagrams, EPLAN macros, ...)

http://www.automation.siemens.com/bilddb/cax_de.aspx?mlfb=3RH2122-1AP00&lang=en

Characteristic: Tripping characteristics, I_t, Let-through current

<https://support.industry.siemens.com/cs/ww/en/ps/3RH2122-1AP00/char>

Further characteristics (e.g. electrical endurance, switching frequency)

<http://www.automation.siemens.com/bilddb/index.aspx?view=Search&mlfb=3RH2122-1AP00&objecttype=14&gridview=view1>

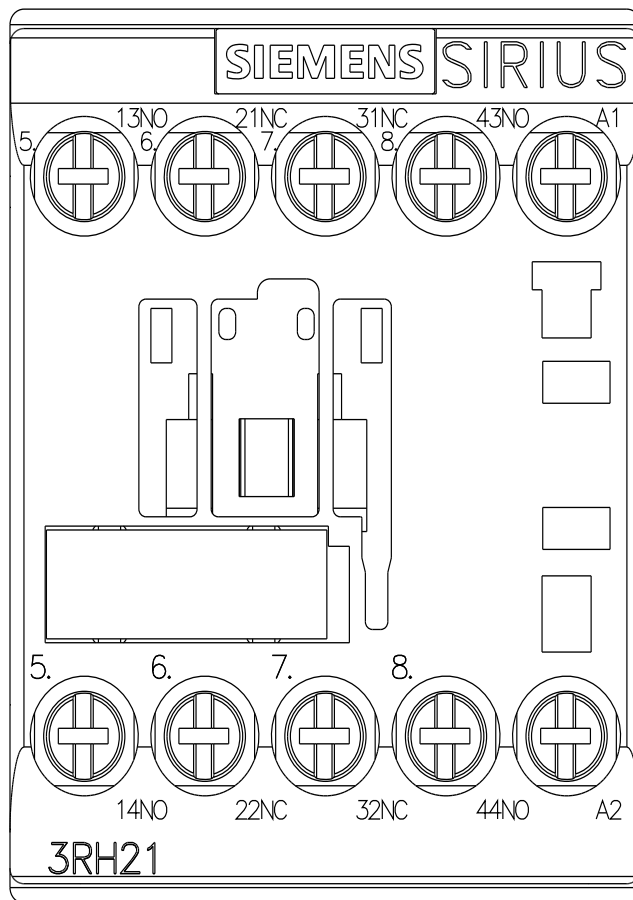
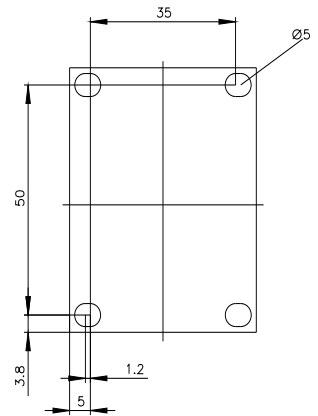
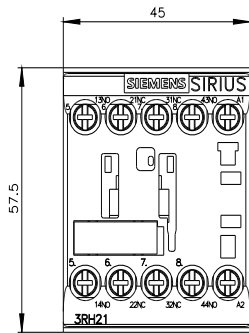

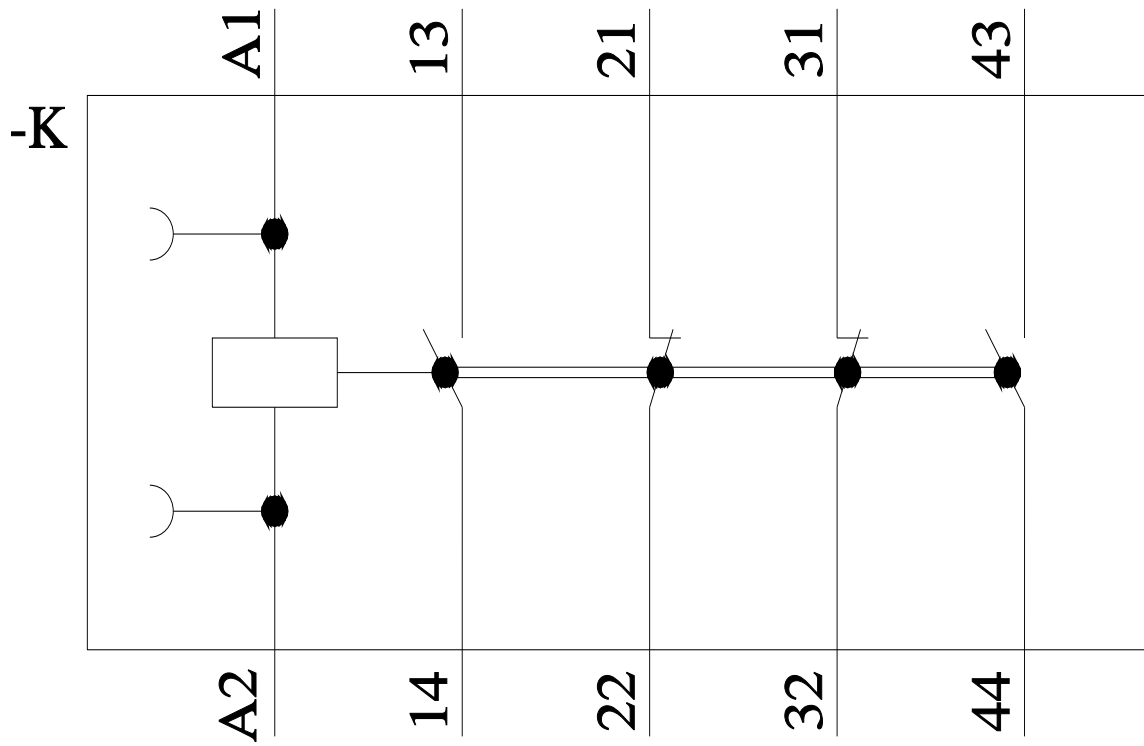

last modified:

5/28/2024 